



MODULAR
SERVICES COMPANY

CONSOLE

Installation Manual

CONSOLE UNITS



INSTALLATION INSTRUCTIONS

1. Remove Fascia Cover for Backbox Installation

The console unit is shipped with the fascia cover attached. Remove the stainless steel screws securing the fascia cover panel and remove the cover. Store these items in a safe place, secure from loss or damage. It should not be necessary to remove any electrical or low-voltage devices (such as a telephone receptacle) attached to the fascia cover. Since the medical gas front bodies are shipped separately, it is not necessary to remove them prior to installing the backboxes.

2. Installation and Adjustment of Backbox

Interior framing (inside edge to inside edge) should be $\frac{3}{4}$ " less than the overall length of the fascia cover dimension (i.e., a 13-gang console has a fascia cover length of 34.344", so the interior framing opening should be 33.594").

The console mounting angles at each end of the console are used to attach the backbox to the interior framing of the structural wall, and are designed for installation into building walls with one layer of $\frac{5}{8}$ " drywall.

After the backbox is mounted, the console may be adjusted in or out to allow for the thickness of the wall finish by loosening the two locking nuts on the inside at each end of the console. Set the front edge of the fascia strips a minimum of $\frac{3}{32}$ " back from the front edge of the designed wall finish when it is installed. When the backbox is set at the correct depth, re-tighten the locking nuts. The backbox may be readjusted during the drywall installation, if necessary; however, it is easier to make this adjustment now.

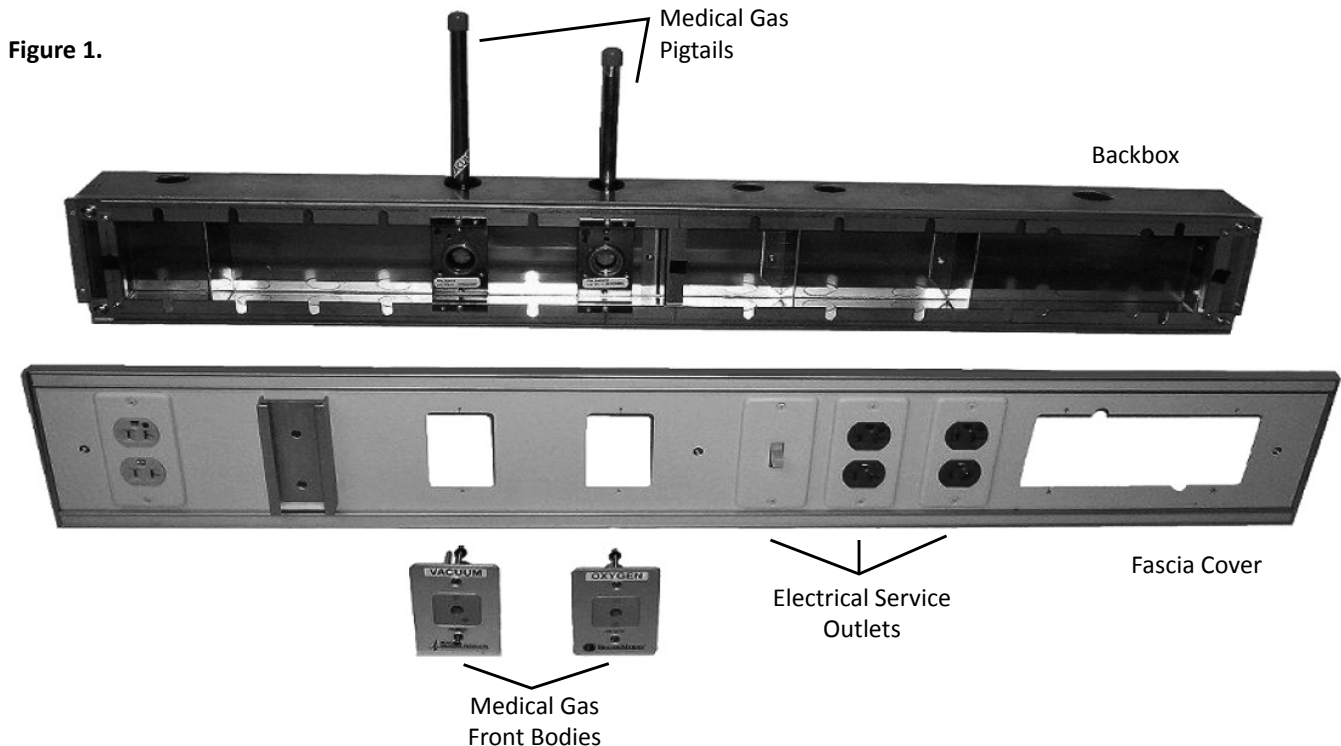

3. Service Connections

At this time, make all medical gas and electrical service connections. All medical gas service connections are to be made in accordance with NFPA 99, as well as any other state and local codes that may apply. All electrical service connections are to be made in accordance with applicable NEC and NFPA 99 codes, as well as any other state and local codes that may apply.

IMPORTANT: Consoles have 3/4" electrical knockouts for each installed device to allow for up to 5/8" drywall. Make sure the medical gas piping, conduit and conduit connectors are positioned so they will not interfere with the installation of drywall. Larger conduits will require larger holes to be punched or drilled behind the leading edge of the pre-existing knockouts.

4. Install Drywall and Wall Finish

After service connections are made to the backbox, the drywall and other wall finish material may be installed around the unit.

5. Reinstall Fascia Cover

After all finishes are applied to the building wall, reinstall the fascia cover by reversing the order of actions in item 1, above. The medical gas front bodies may also be installed at this time. If the backbox depth requires final adjustment, loosen the four locking nuts at the corners and adjust as required, then re-tighten.

Figure 2.

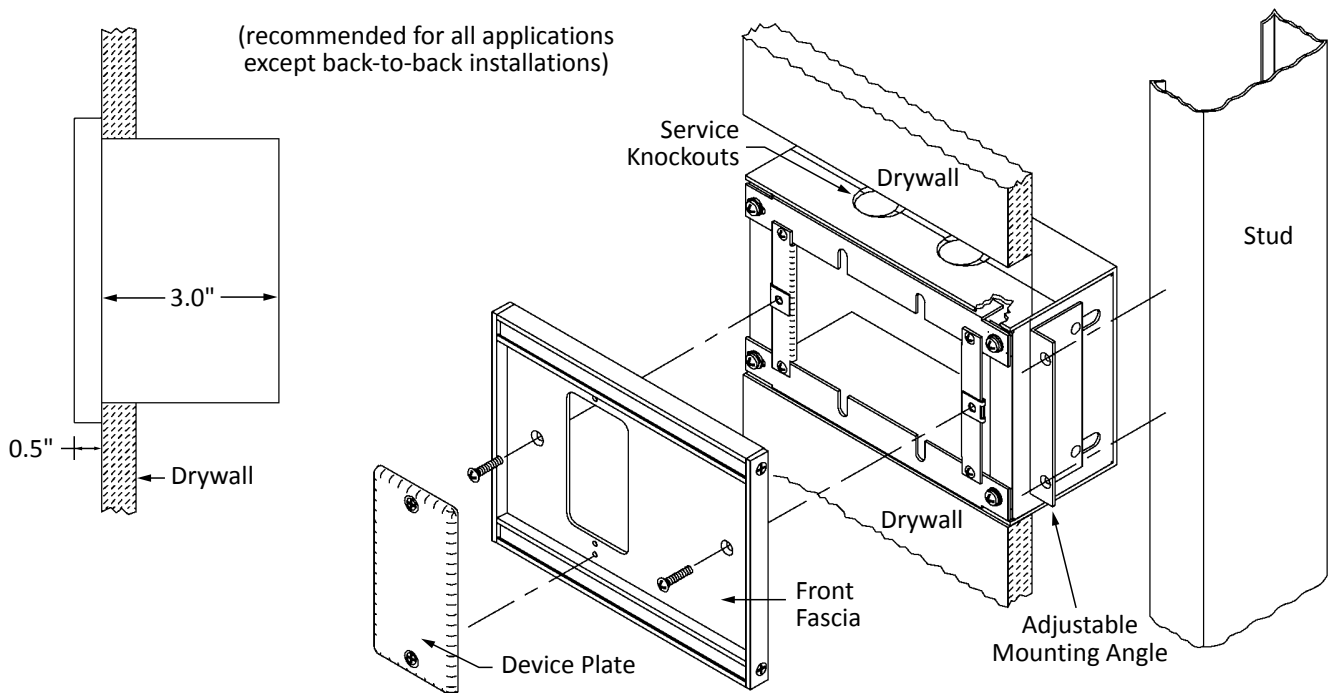

INSTALLATION TERMS AND CONDITIONS

Each Modular Services unit, or unit section, shall be completely pre-wired for normal, emergency and low voltage according to the approved submittal. Communication devices and wiring shall be supplied by others. These devices include nurse call, television, code blue, telephone, monitor jacks, etc.

The customer shall be responsible for all electrical conduits, wiring hook-up of electrical services, and if applicable, interconnect wiring between sections. All hardware light fixtures shall be installed, wired and lamped by contractor. After installation is complete, the customer shall test equipment functions, as well as electrical receptacles and ground, in accordance with the National Electrical Code.

Medical gas contractor shall be responsible for piping and hook-up of all medical gas services. The medical gas contractor shall be responsible for purging, pressure testing, gas identification, and system certification in accordance with NFPA 99.

Modular Services Company shall have no responsibility or liability for delays, however caused. Owner shall hold Modular Services harmless from damages or injury related to any failure or neglect of owner, its employees, agents or licensees. Modular Services shall not be liable for consequential damages; makes no warranties, expressed or implied; and assumes no obligation other than those expressly contained herein.

WARRANTY

Modular Services Company warrants that all equipment assemblies shall be free from defects in material and workmanship for a period of 12 months from date of the owner's acceptance to the installing contractor or the date the equipment is put into service, whichever comes first. Warranty excludes electric lamps and/or any material not furnished by Modular Services. Warranty does not cover damage due to improper installation and/or abuse.

It is the responsibility of the customer to report any noted product deficiencies to Modular Services immediately upon discovery. It is the responsibility of Modular Services to expediently resolve the discrepancy. Any modification made to the product without the written authorization from Modular Services will void this warranty.

Also, in the event product modifications or repairs are made without the written consent of Modular Services, Modular Services shall not be held liable for any cost associated with the modification or repair.

There are no warranties of fitness which extend beyond the description on the face hereof.



109 NE 38th St. • Oklahoma City, OK 73105
Tel: 800.687.0938 • Fax: 405.528.0368
www.headwalls.com • info@headwalls.com